





Midsummer

Roof Mount Solar Array Installation Guide



Components List

Rails	Splice	End Clamp	Mid Clamp	L Feet 05
				
AL 6005-T5	AL 6005-T5	AL 6005-T5	AL 6005-T5	SUS 304

Roof Hook (Flat Tiles)	Roof Hook (Horizontal)	Roof Hook 04 (Slate tile)	Roof Hook (Vertical)
			
SUS 304	SUS 304	SUS 304	SUS304

For Safe Installation Work

This manual contains critical information regarding electrical and mechanical installation and safety information which you should know before starting installation.



Installation Caution

- Stop work in adverse weather conditions. Solar modules can be caught in the wind, causing you to fall.
- Never step or sit on the glass surface of a solar module. The glass may break, resulting in shock or bodily injury. The module may also stop generating power.
- Always use the supplied parts to attach the solar modules and mounts. Use of weaker parts, such as screws that are too short, is dangerous and may cause the solar modules or mounts to fall.
- Always use the specified tools. The solar modules or mounts may fall if the installation is not strong enough, for example when parts are not tightened sufficiently.
- Do not modify or cut parts. Doing so is dangerous. Safety cannot be guaranteed.
- The product should be installed and maintained by qualified personnel. Keep unauthorized personnel away from solar modules.

POINTS TO CHECK

- Determine the wind loads for the installation site. Check with your local building and safety department for the specific requirements. Make certain that the roof structure can support the live and dead loads resulting from the installation of the PV array.
- Install solar modules facing south, if possible. Installations facing east and west are also possible, although the amount of power generated will be lower.

Installation Steps

Mounting the Roof Hooks

Determine the position of the roof hooks according to your design.

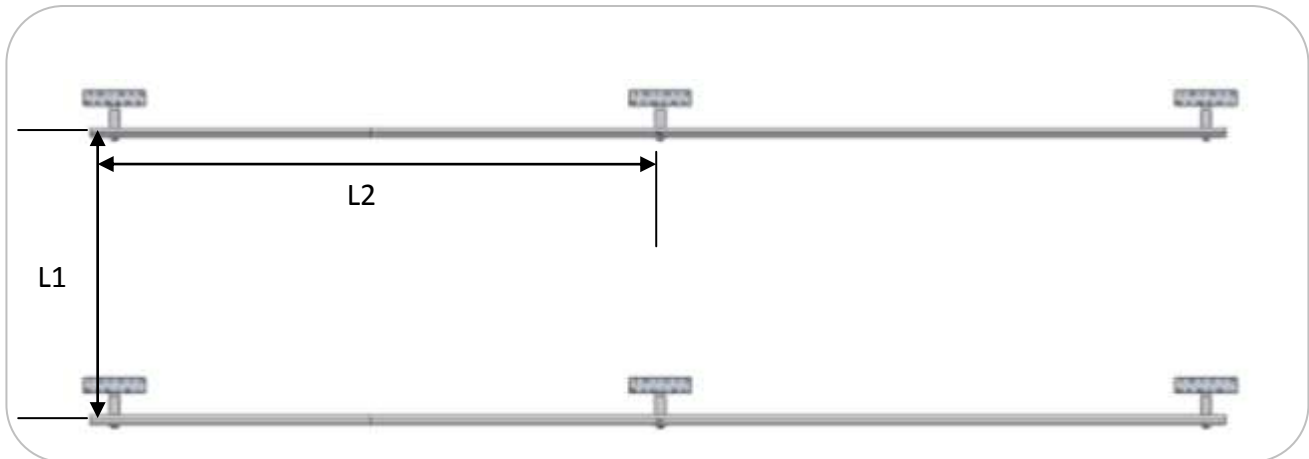

L1: Distance between rails is $0.6 \times$ panel length.

L2: Distance between roof hooks, no longer than 1200mm. $L2 < 1200\text{mm}$
(Distance between roof hooks, no longer than 600mm)

1. Remove the roof tiles at the marked positions or simply lift them up slightly.

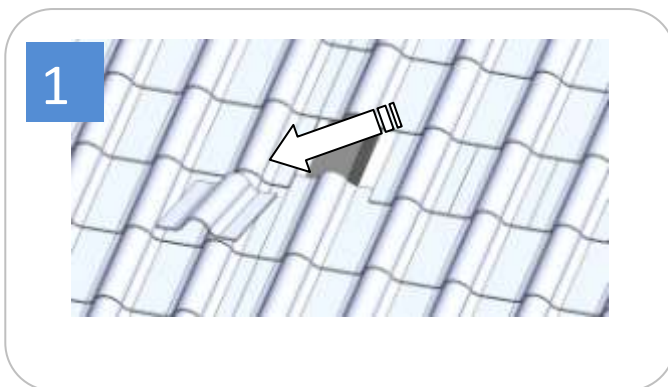

2. Insert the roof hook to the wooden beam. Fix the roof hooks with screws.



3. Cover the hooks with tile

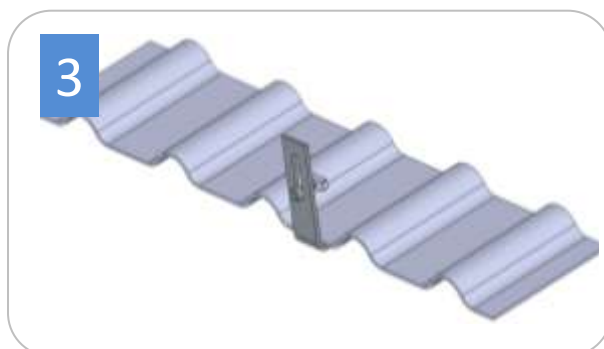

The roof hook must not press against the roof tile. Place it flat. If necessary, shim the roof hook with wood.

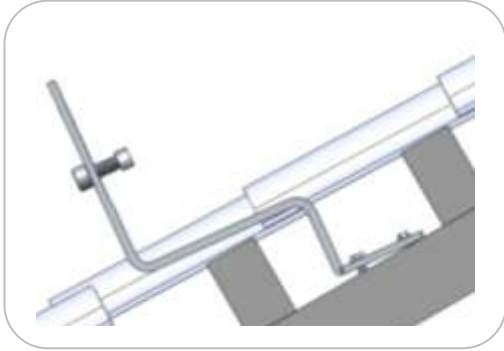

Wrong !

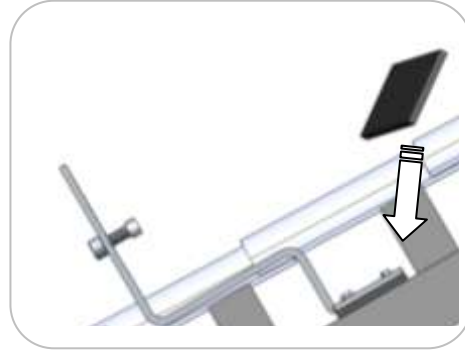

Correct !

If necessary, use an angle grinder to cut a concavity in the tile that covers the roof hook at the point where the roof hook comes through. (Caution! Avoid using fixed roof hook as a ladder, as this extreme point load could damage the tile below.)

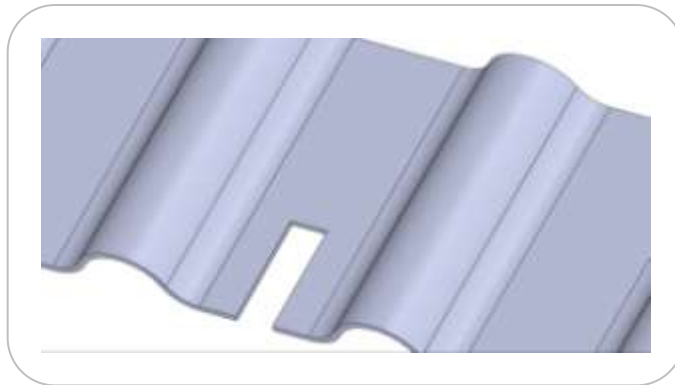

Note: Installation of L Feet

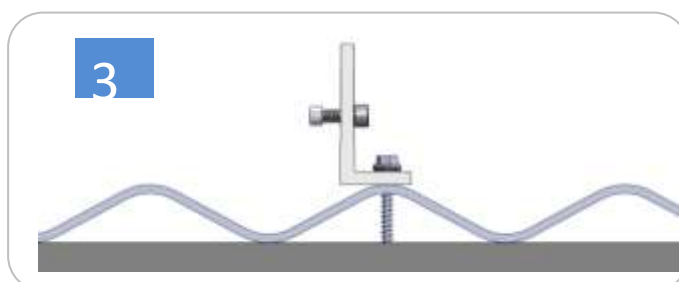
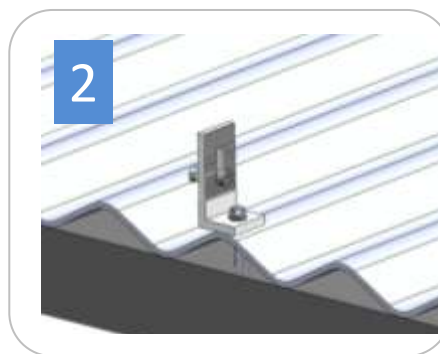

Rail Installation Steps

Installation of the rails on roof hooks. Install the rails on the roof hooks loosely at first, using T-screw.

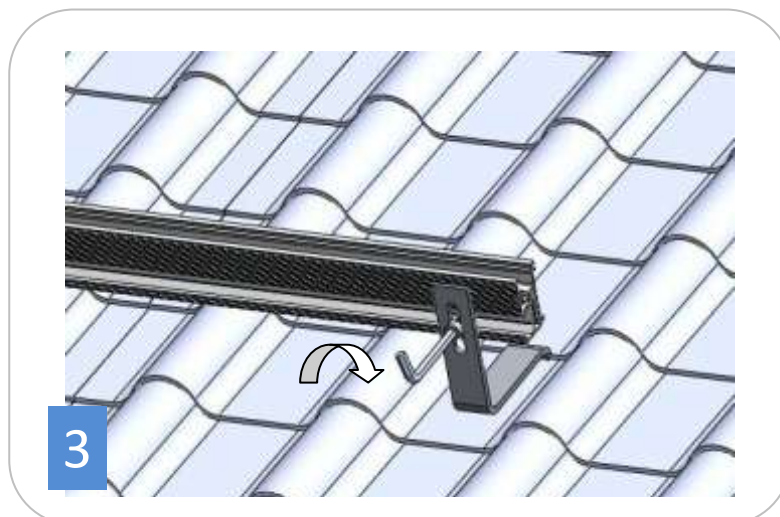



Rail Splicing Steps

Multiple rails are spliced together as follows. Slide the splice on the rear side of the pre-assembled rails and fasten the first bolt firmly. Then slide the next rail into the splice and tighten the second bolt. An expansion gap at the rail joints is suggested. Leave a gap of about a finger width.

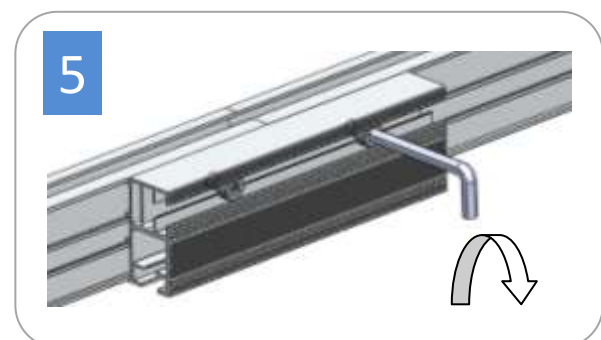
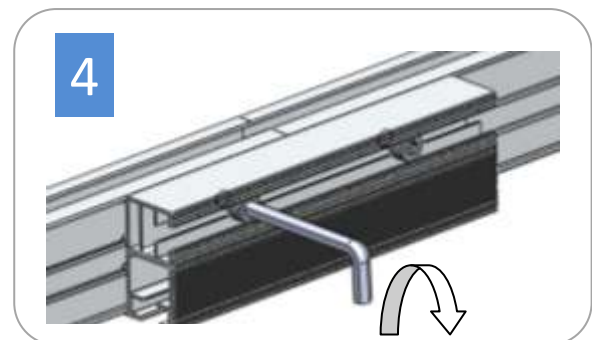
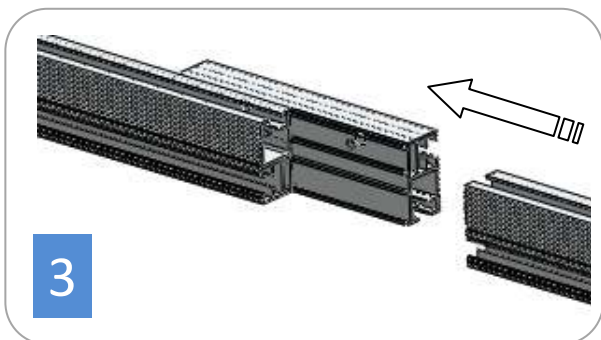

Clamp Installation Steps

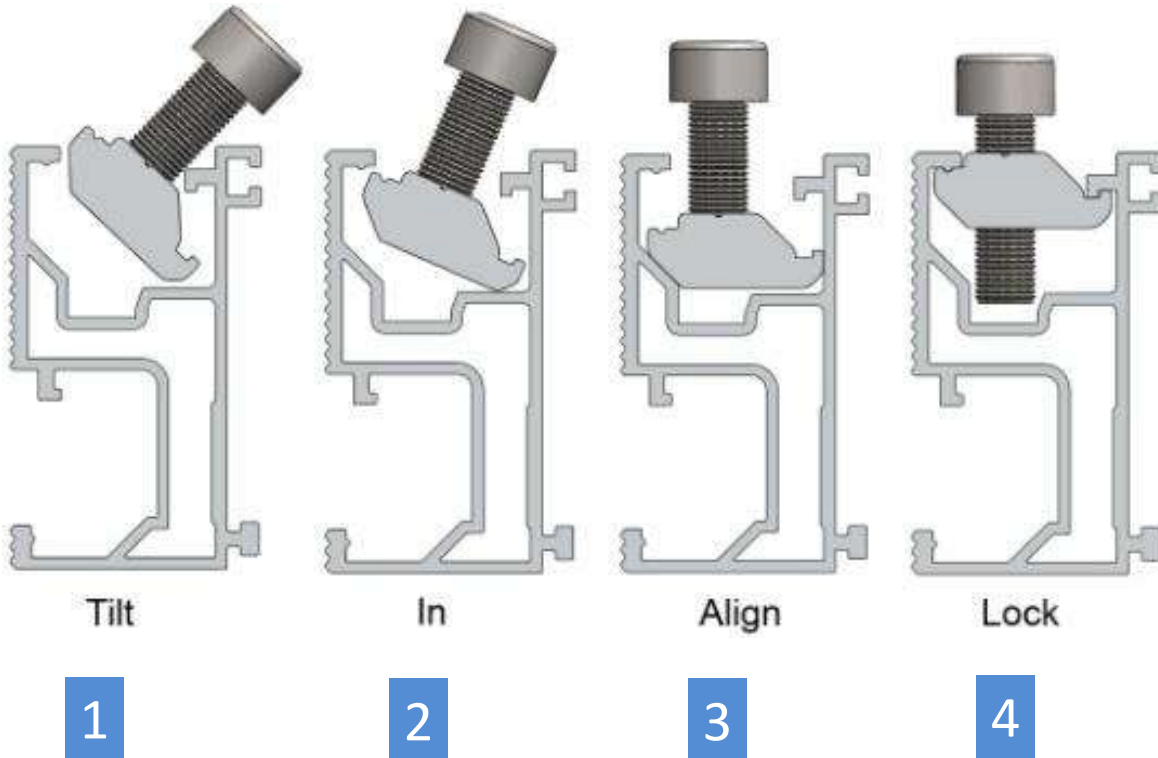

Module Mounting

Place the first module of the bottom row. Slide the end clamp tightly against the module and fasten it. Install the end clamp and mid clamps.

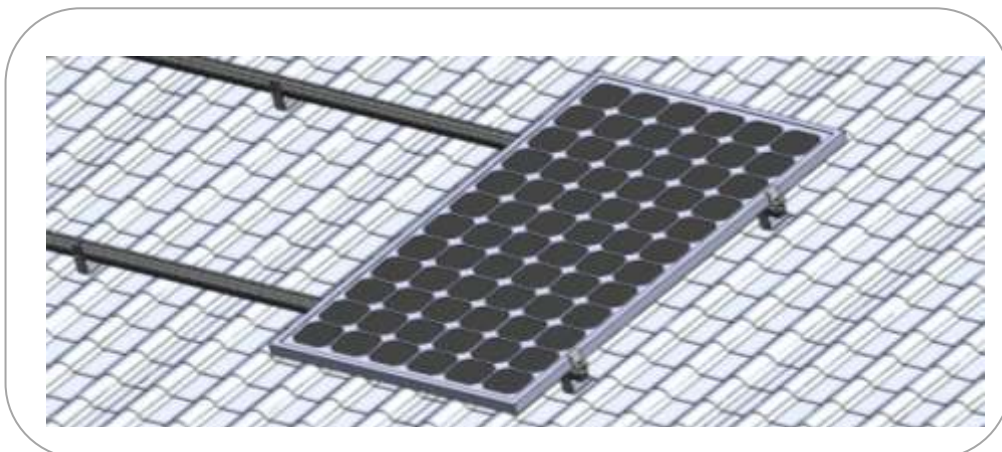

The rail should leave a space of 25mm-30mm:

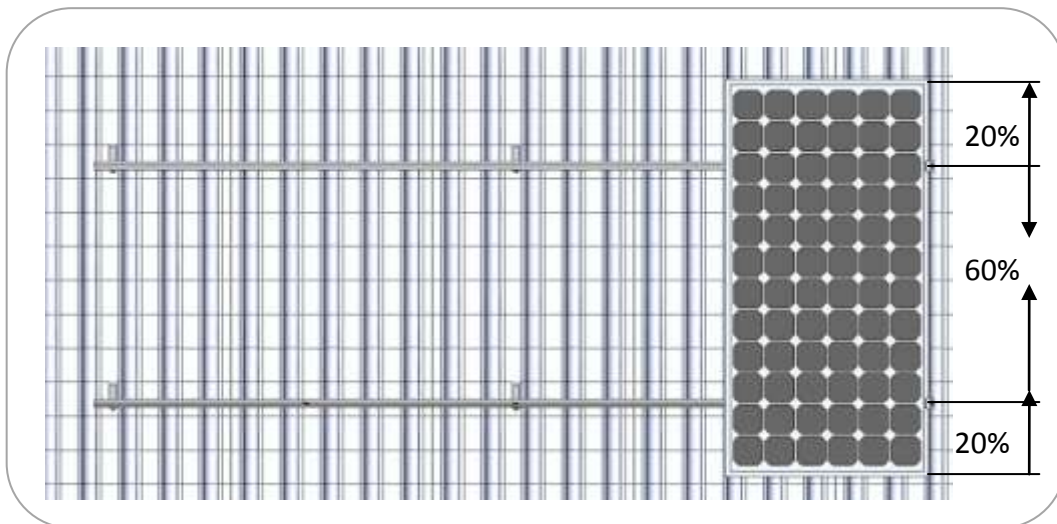
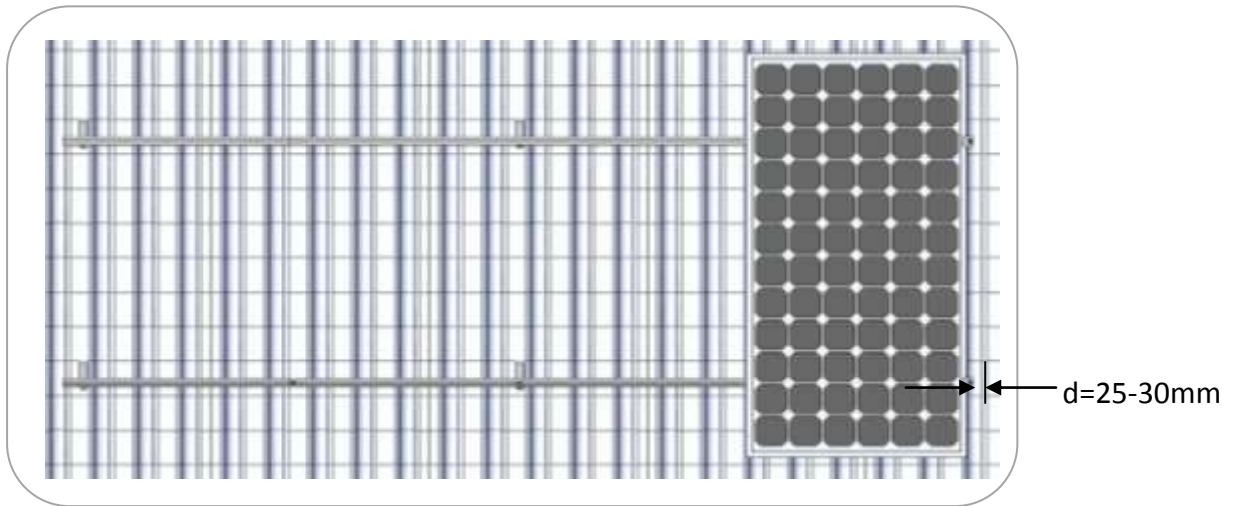

Slide the next module against the installed module. Fasten the mid clamp. Install other modules and clamps in this way. Keep the modules even.

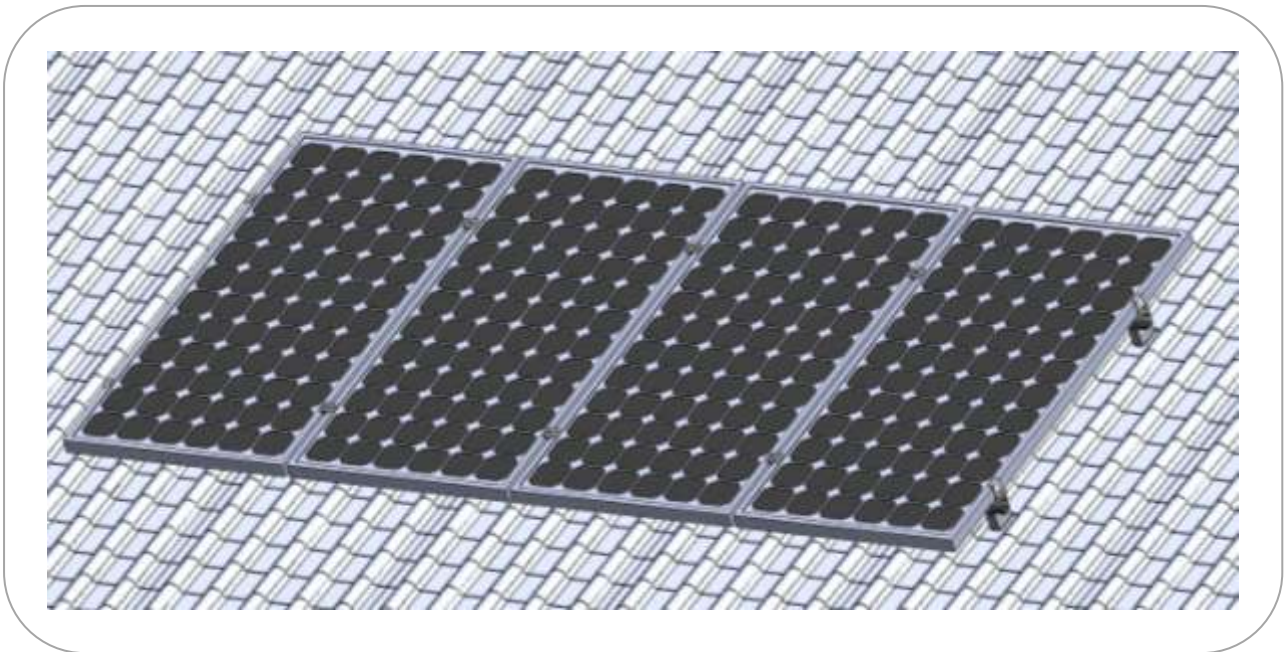
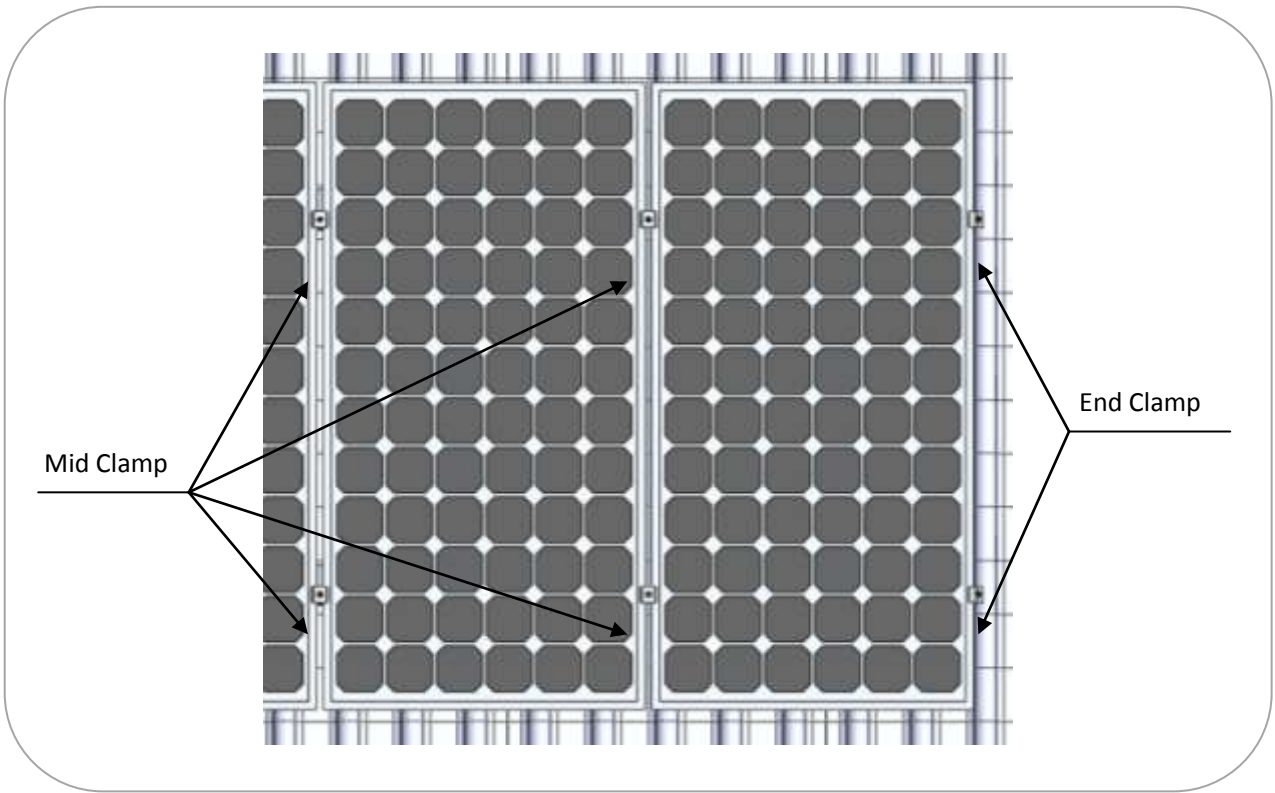

The array installation is complete.